

HYDROGENERÁTOR ZUBOVÝ OT200P30D/G28P2

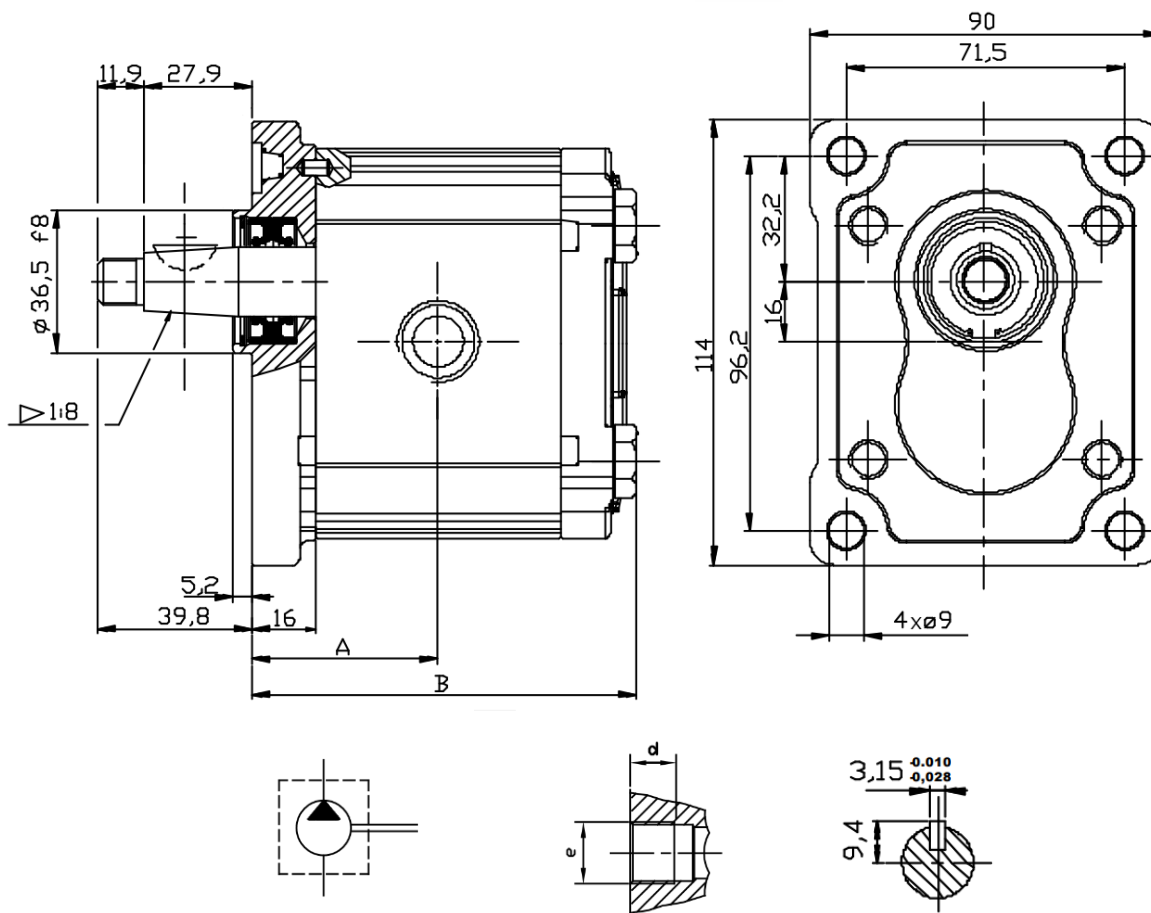

Typ	Geometrický objem [cm ³ /ot.]	Max. pracovní tlak [bar]	Max. tlaková špička [bar]	Max. rychlost [ot/min.]	A [mm]	B [mm]	Rozměry			
							Vstup		Výstup	
							e	d [mm]	e	d [mm]
OT200P04	4,10	250	300	4000	40,00	83,50	G 1/2"	14	G 1/2"	14
OT200P06	6,20	250	300	3500	41,50	86,50				
OT200P08	8,20	250	300	3500	43,00	89,50				
OT200P11	11,20	250	300	3500	45,15	93,80				
OT200P14	14,00	240	300	3000	47,15	97,80	G 3/4"	16	G 1/2"	14
OT200P16	16,00	240	300	3000	48,60	100,7				
OT200P20	20,00	200	240	3000	51,50	106,5				
OT200P22	22,50	170	210	2500	57,36	118,2				
OT200P25	25,10	170	210	2500	59,25	122,0				
OT200P28	28,00	140	180	2500	61,36	126,2				
OT200P30	30,00	130	170	2000	62,75	129,0				

Objednací klíč

